

BIG

**GEOMETRIC
FIGURES**



TABLE OF CONTENTS

Teacher Tips	3
Content Vocabulary	5
Two Dimensional Shape Sort	14
Classifying Quadrilaterals	21
Vocabulary Sort	26
Identify 2D Attributes	34
3D Attribute Match	39
Figure Hunt	45
Describe It	49
QR Codes	54
Match Mine	59
Geometry Monster	63
Test Bridge Questions	67

TO THE TEACHER

- This product is meant to be a no frills, all action tool for cementing the concept of geometric figures in preparation for standardized testing.
- Each activity can be completed in a variety of ways to fit your classroom needs.
- It was created with the following standards in mind:
 - TEKS
 - 3.6(A) classify and sort two- and three-dimensional figures, including cones, cylinders, spheres, triangular and rectangular prisms, and cubes, based on attributes using formal geometric language
 - Common Core
 - CCSS.MATH.CONTENT.3.G.A.1 Understand that shapes in different categories (e.g., rhombuses, rectangles, and others) may share attributes (e.g., having four sides), and that the shared attributes can define a larger category (e.g., quadrilaterals). Recognize rhombuses, rectangles, and squares as examples of quadrilaterals, and draw examples of quadrilaterals that do not belong to any of these subcategories.

PREP RECOMMENDATIONS

- Each activity is created in black and white to conserve color ink
 - Using colored paper to differentiate different parts in each activity or the different stations will help students to stay organized.
- If you plan to use the activities for small group or partner activities over time, I would recommend laminating them for durability.

CONTENT VOCABULARY

classify

use

three-dimensional figures

cylinder

triangular prism

cube

octagon

quadrilateral

hexagon

square

characteristic

vertex/vertices

face

shape

solid

trapezoid

sort

two-dimensional figures

circle

sphere

rectangular prism

cube

pentagon

rectangle

triangle

figure

edge

parallelogram

side

rhombus

classify

sort

use

two-
dimensional
figures

cone

cylinder

sphere

three-
dimensional
figures

triangular
prism

rectangular
prism

cube

attributes

octagon

• polygon

quadrilateral

pentagon

hexagon

rectangle

square

triangle

characteristic

figure

vertex

vertices

edge

face

parallelogram

shape

side

solid

rhombus

trapezoid

TWO DIMENSIONAL SHAPE SORT

Sort two dimensional figures as triangles, quadrilaterals, polygons, or not polygons.

TEACHER SUGGESTIONS

TWO DIMENSIONAL SHAPE SORT

- In this activity students are asked to sort two dimensional figures such as triangles, quadrilaterals, polygons, or non-polygons.
- This activity can be used in a variety of ways:
 - ✓ Small group with teacher guidance
 - ✓ A partner activity for practice
 - ✓ Independently to assess

Materials

Included:

- Geometric Figures
- Sorting Mat
- Recording Sheet
- Answer Key

Not Included:

- Pencil

TRIANGLES

QUADRILATERALS

pentagons

POLYGONS

NOT POLYGONS

A

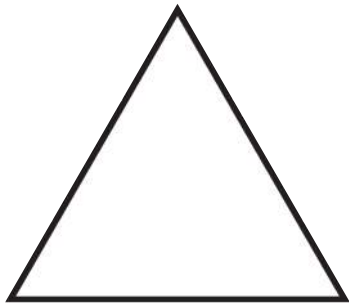

B

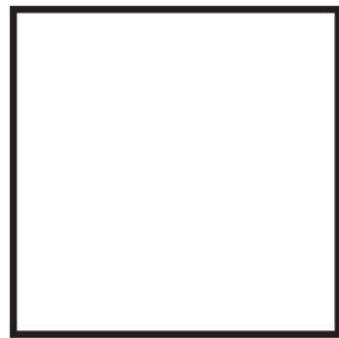

C

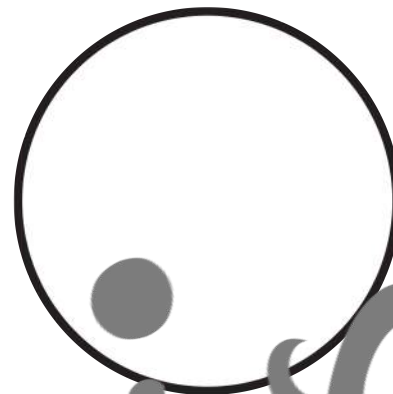

D



E



F



G

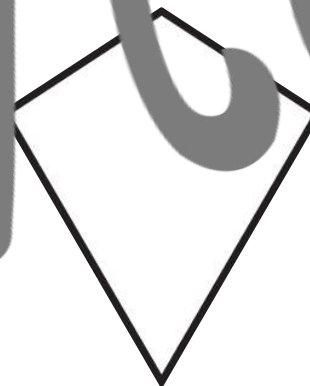

H

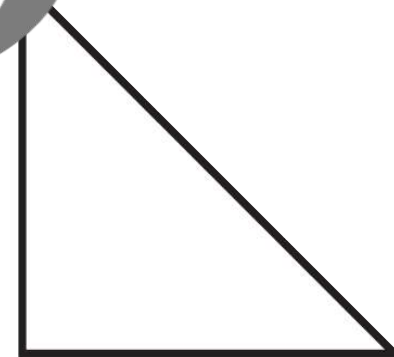

I

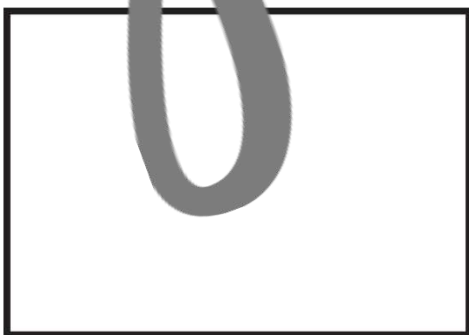

J

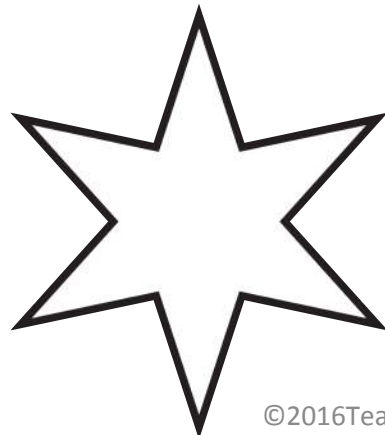

K

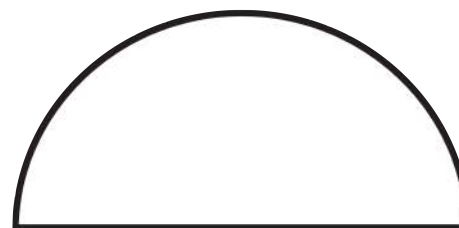

L

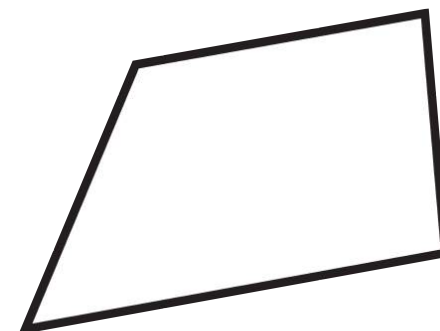

M

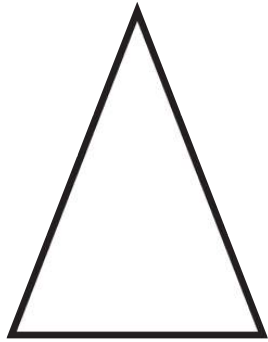

N



O



P



Q

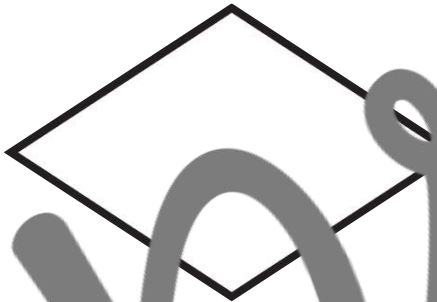

R



S

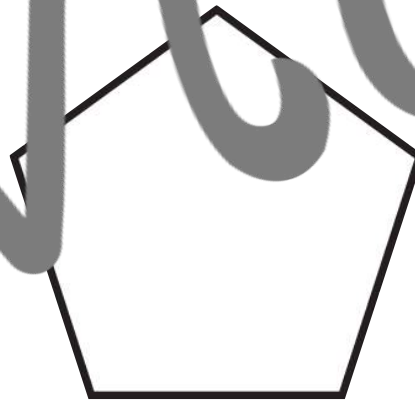

T

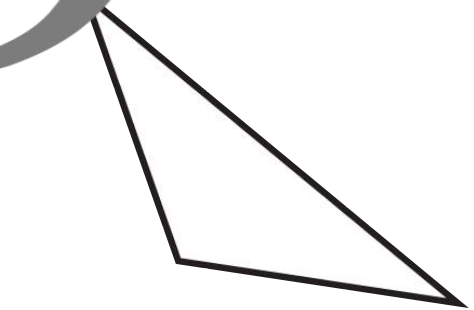

U

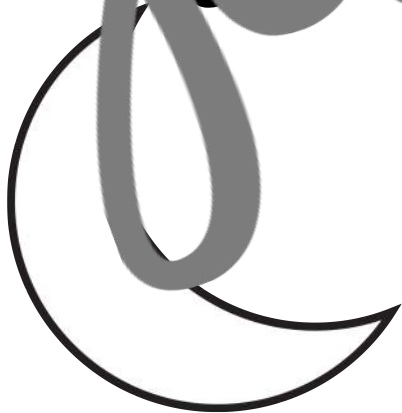

V

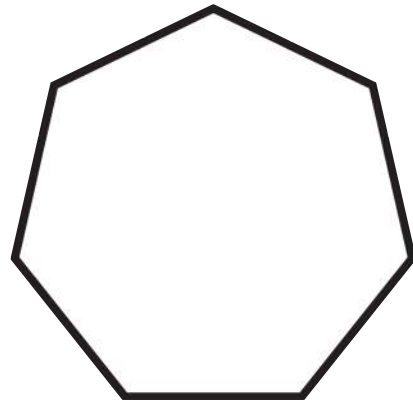

W

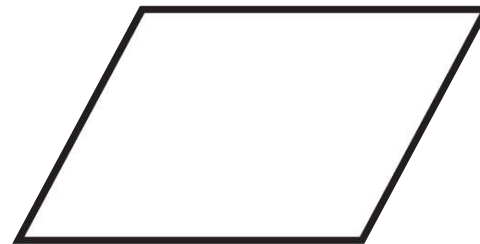

X

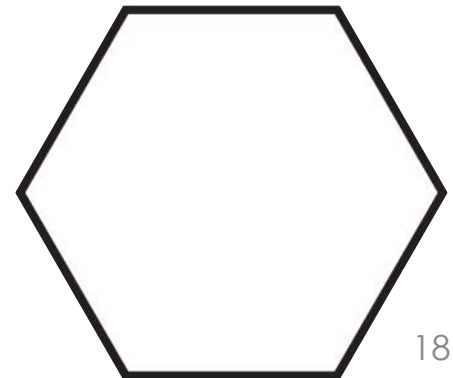

Review

Name _____

Date _____

TWO DIMENSIONAL SHAPE SORT RESPONSE SHEET

Sort each shape as a triangle, quadrilateral, polygon, or not a polygon.

Triangle	Quadrilateral	Polygon	Not a Polygon

previews

TWO DIMENSIONAL SHAPE SORT ANSWER KEY

Triangle	Quadrilateral	Polygon	Not a Polygon
A	B	D	C
H	G	J	E
M	I	O	F
T	L	P	K
	N	S	R
	Q	V	U
	W	X	

CLASSIFYING QUADRILATERALS

Complete the bracket map by classifying the quadrilaterals by their attributes.

TEACHER SUGGESTIONS

CLASSIFYING QUADRILATERALS

- In this activity students are asked to complete a bracket map by classifying the quadrilaterals by their attributes.
- This activity can be used in a variety of ways:
 - ✓ Small group with teacher guidance
 - ✓ A partner activity for practice
 - ✓ Independently to assess

Materials

Included:

- Quadrilaterals
- Bracket Map
- Recording Sheet
- Answer Key

Not Included:

- Pencil

Use each of the figures below as models to complete the bracket map. Make sure to label each figure with their name.

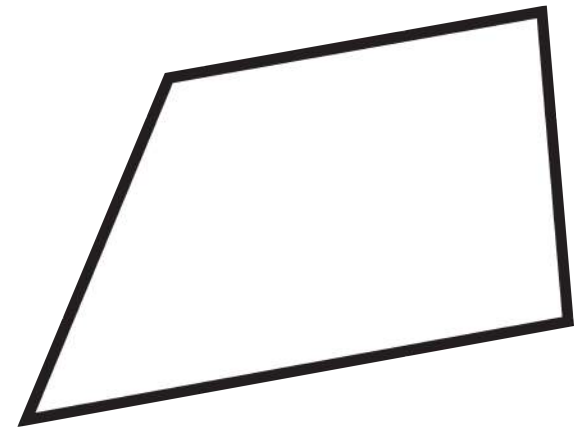
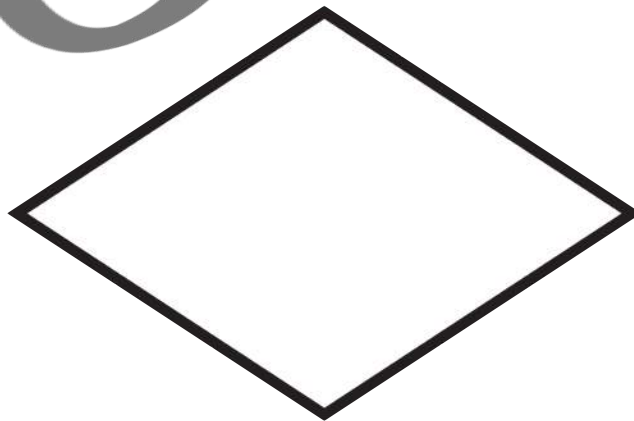
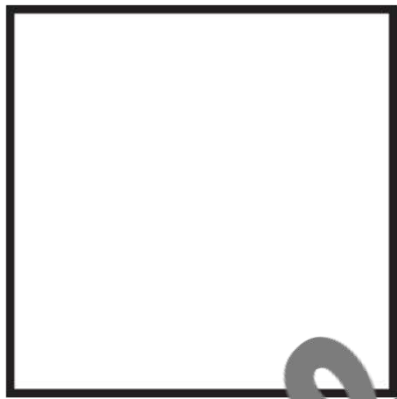

Name _____

Date _____

previews

ANSWER KEY

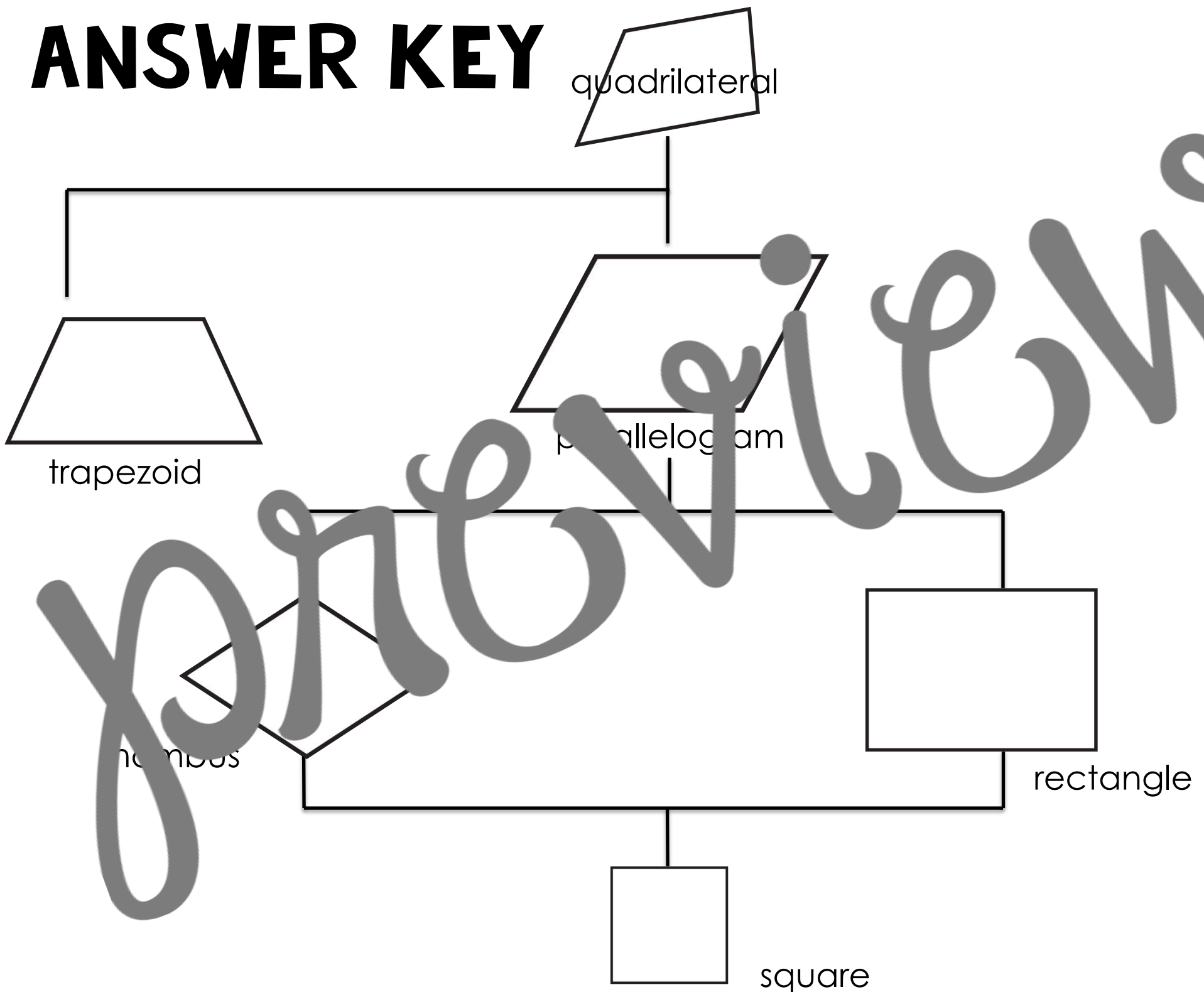

previews

VOCABULARY SORT

Sort the names, figures, and attributes as either two or three dimensional.

TEACHER SUGGESTIONS

VOCABULARY SORT

- In this activity students are asked to sort the names, figures, and attributes as either two or three dimensional.
- This activity can be used in a variety of ways:
 - ✓ Small group with teacher guidance
 - ✓ A partner activity for practice
 - ✓ Independently to assess

Materials

Included:

- Figures
- Names
- Attributes
- Sorting Mat
- Recording Sheet
- Answer Key

Not Included:

- Pencil

VOCABULARY SORTING MAT

Sort each item as 2D or 3D.

2D

3D

pretzel
view

A

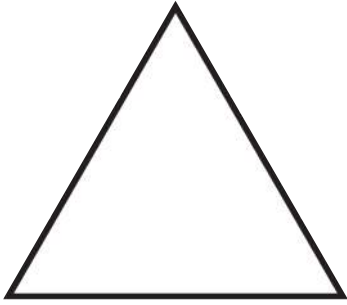

B

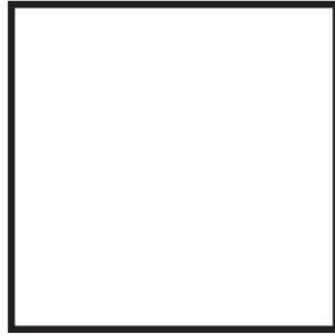

C

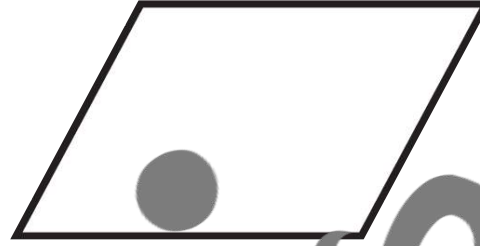

D

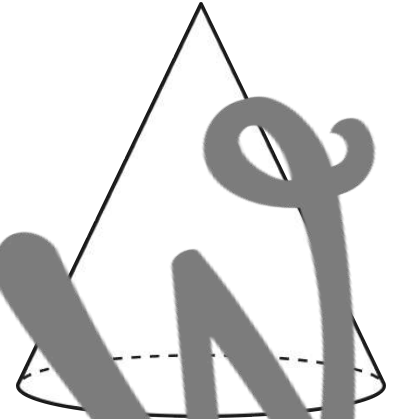

E

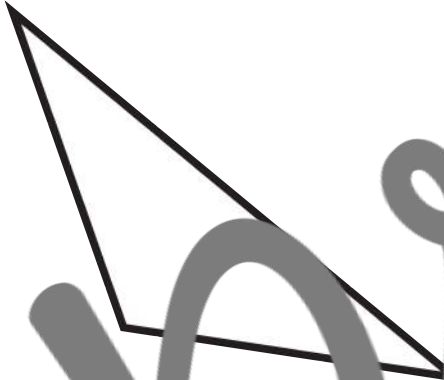

F

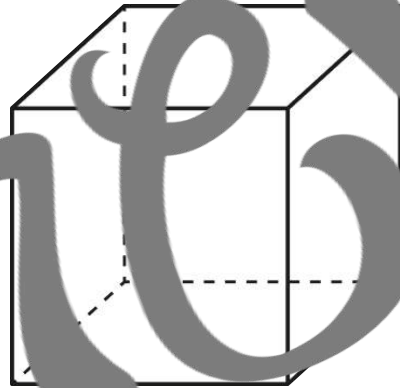

G

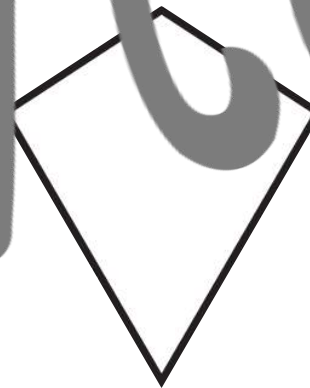

H

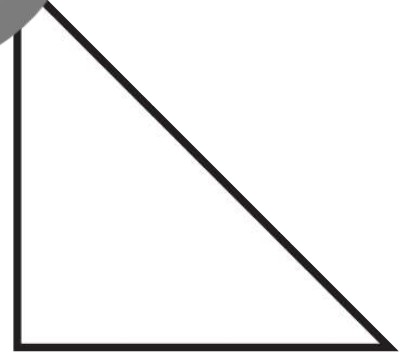

I

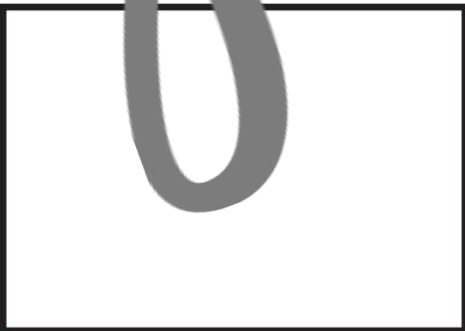

J

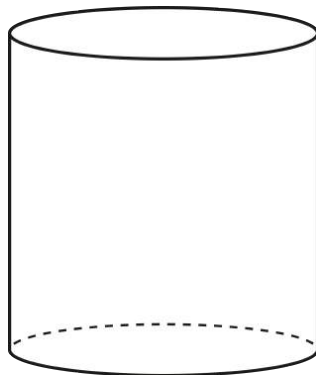

K

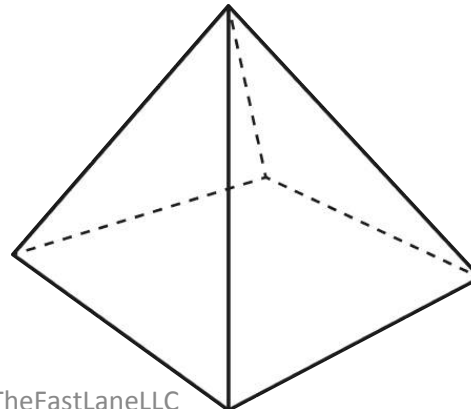

L

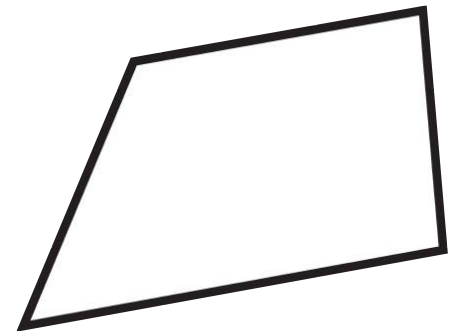

M

N

O

P

cube

corner

rhombus

prism

Q

R

S

T

triangle

vertex

square

face

U

V

W

X

side

edge

pyramid

vertices

prisms

Y

sphere

Z

cylinder

1

polygon

2

circle

3

triangular
pyramid

4

rectangle

5

right
triangle

6

oval

7

square
pyramid

8

hemisphere

9

cone

10

kite

Name _____ # _____ Date _____

VOCABULARY SORT RESPONSE SHEET

Sort each figure, attribute, or name as being 2D or 3D.

2 Dimensional	3 Dimensional

one view

VOCABULARY SORT ANSWER KEY

2 Dimensional		3 Dimensional	
A	N	D	R
B	O	E	I
C	Q	J	V
F	S	K	W
G	T	L	X
H	1	M	Y
I	2	P	Z
J	5	3	7
6	10	8	9

IDENTIFY

2D

ATTRIBUTES

Label each figure and identify the lines and angles in each 2D figure.

TEACHER SUGGESTIONS

IDENTIFY 2D ATTRIBUTES

- In this activity students are asked to name each figure and identify the lines and angles in each 2D figure.
- This activity can be used in a variety of ways:
 - ✓ Small group with teacher guidance
 - ✓ A partner activity for practice
 - ✓ Independently to assess

Materials

Included:

- 2D Figure Cards
- Recording Sheet
- Answer Key

Not Included:

- Pencil

1

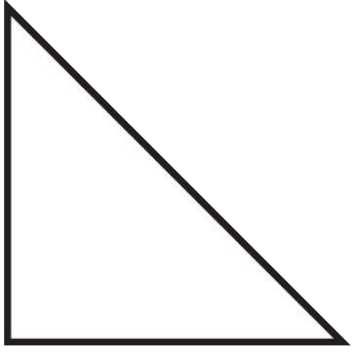

2

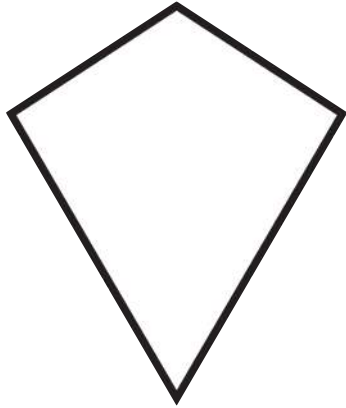

3

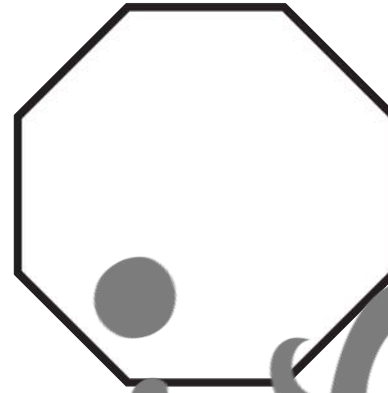

4



5



6



7

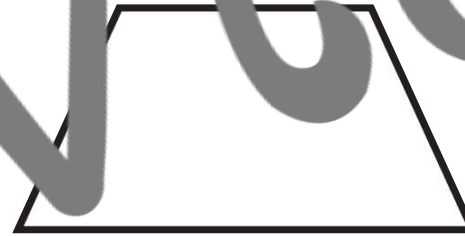

8

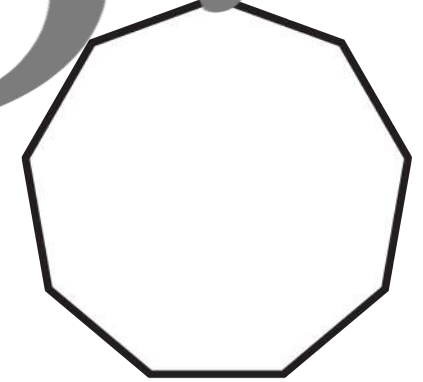

9

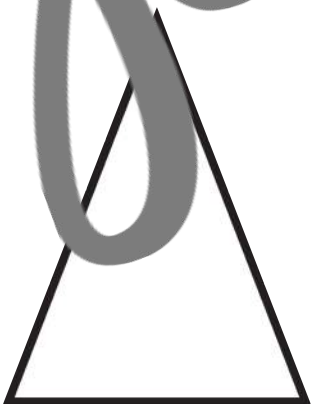

10

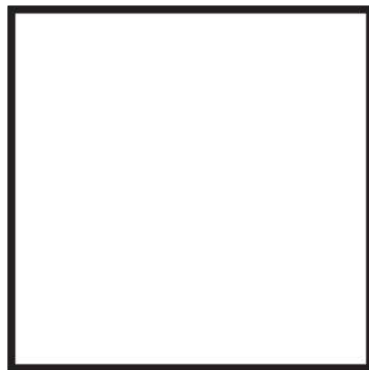

11



12

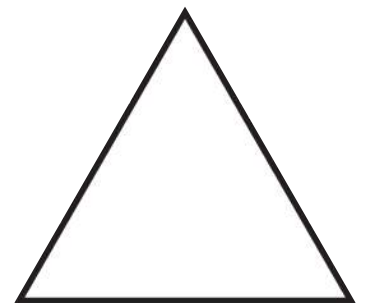

Name _____

Date _____

IDENTIFY 2D ATTRIBUTES RESPONSE SHEET

Name each 2D figure and identify its attributes.

1	2	3
4	5	6
7	8	9
10	11	12

IDENTIFY 2D ATTRIBUTES

ANSWER KEY

1 triangle 3 sides 3 angles	2 kite/quadrilateral 4 sides 4 angles	3 octagon 8 sides 8 angles
4 pentagon 5 sides 5 angles	5 square 4 sides 4 angles	6 parallelogram 4 sides 4 angles
7 trapezoid 4 sides 4 angles	8 nonagon 9 sides 9 angles	9 triangle 3 sides 3 angles
10 square 4 sides 4 angles	11 rectangle 4 sides 4 angles	12 triangle 3 sides 3 angles

3D. ATTRIBUTE MATCH

Match each 3D figure to its
attribute description.

TEACHER SUGGESTIONS

3D ATTRIBUTE MATCH

- In this activity students are asked to match each 3D figure to its attribute description.
- This activity can be used in a variety of ways:
 - ✓ Small group with teacher guidance
 - ✓ A warmer activity for practice
 - ✓ Independently to assess

Materials

Included:

- 3D Figures
 - Attribute Descriptions
 - Recording Sheet
 - Answer Key
- Not Included:
- Pencil

1

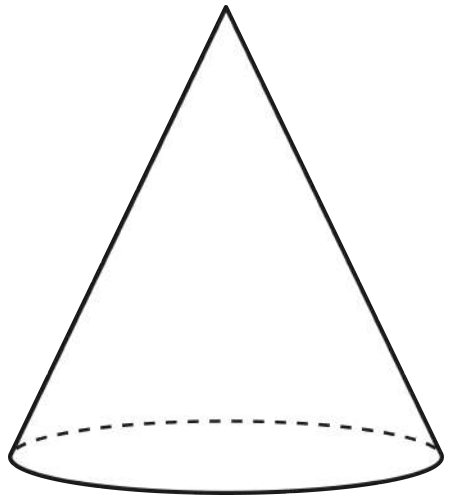

2

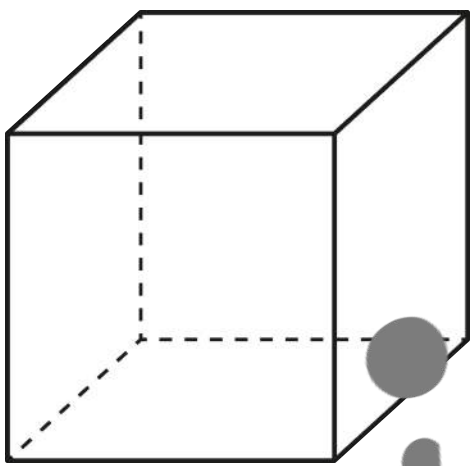

3



4

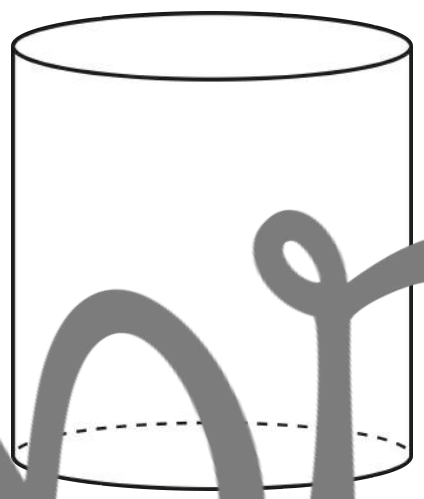

5

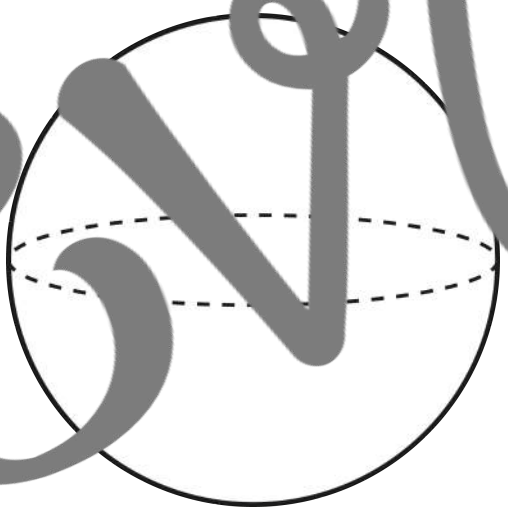

6

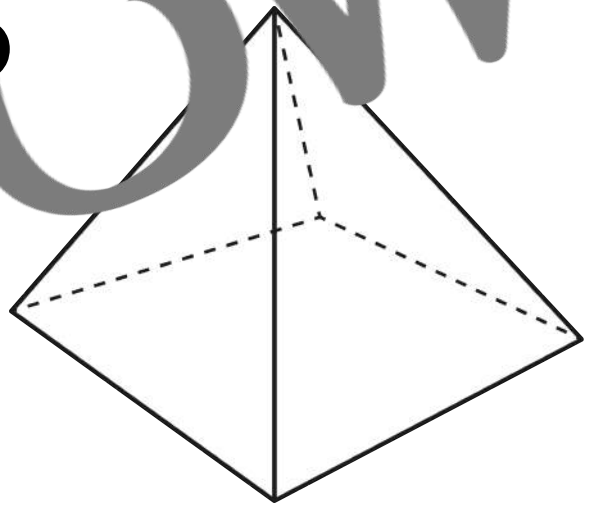

7

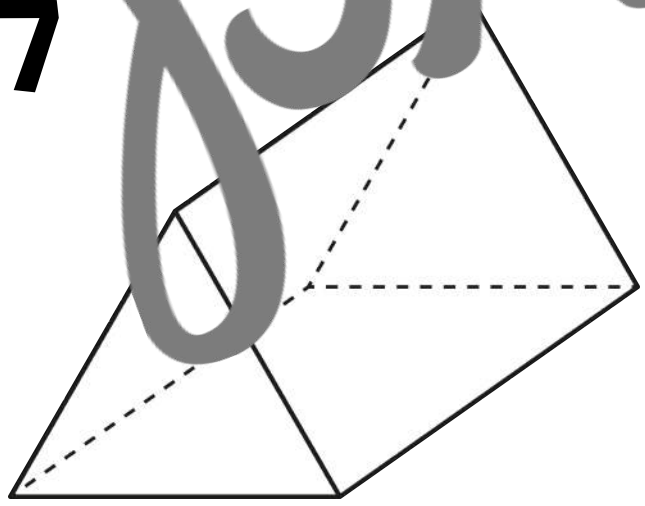

8

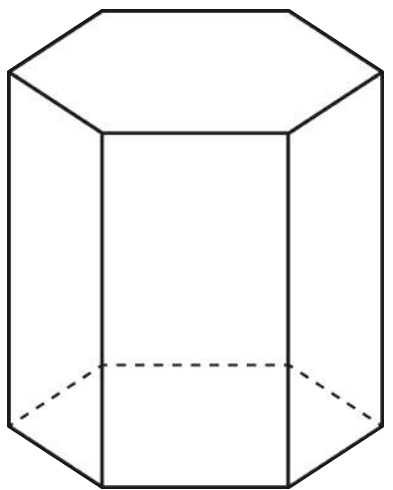

9

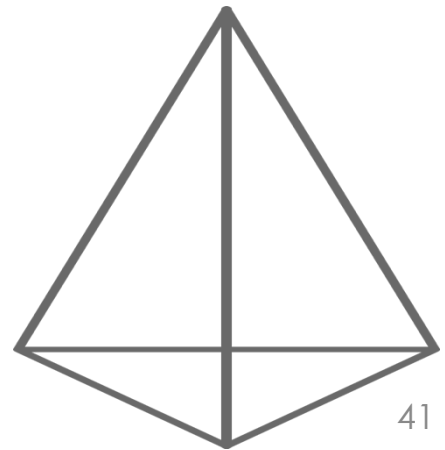

Teaching in the Fast Lane

G

one circular face and one curved surface

E

six square faces, eight vertices, and twelve edges

B

six rectangular faces, eight vertices, and twelve edges

D

two circular faces and one curved surface

A

no faces, edges, or vertices all points are equidistant from the center

I

one square face, four triangular faces, five vertices, and eight edges

H

two triangular faces, three rectangular faces, nine edges, and six vertices

C

two hexagonal faces, six rectangular faces, eighteen edges, and twelve vertices

F

four triangular faces, six edges, and four vertices

Name _____

Date _____

3D ATTRIBUTE MATCH RESPONSE SHEET

Match each 3D figure to its attributes.

1	2	3
4	5	6
7	8	9

3D ATTRIBUTE MATCH ANSWER KEY

1 G	2 E	3 B
4 D	5 A	6 I
7 H	8 C	9 F

FIGURE HUNT

Find geometric figures in the real world, and then sketch and record their attributes.

TEACHER SUGGESTIONS

FIGURE HUNT

- In this activity students are asked to find geometric figures in the real world, and then sketch and record their attributes.
- This activity can be used in a variety of ways:
 - ✓ Small group with teacher guidance
 - ✓ A partner activity for practice
 - ✓ Independently to assess

Materials

Included:

- Recording Sheet

Not Included:

- Pencil
- Answer Key

Name _____ # _____ Date _____

FIGURE HUNT RESPONSE SHEET

Find geometric figures in the real world, and then sketch and record their attributes.

SKETCH	FIGURE NAME	ATTRIBUTES

previews

SKETCH

FIGURE NAME

ATTRIBUTES

penneview

DESCRIBE IT

Name and describe each
geometric figure using your
geometric language.

TEACHER SUGGESTIONS

DESCRIBE IT

- In this activity students are asked to name and describe the attributes of each geometric figure using geometric language.
- This activity can be used in a variety of ways:
 - ✓ Small group with teacher guidance
 - ✓ A partner activity for practice
 - ✓ Independently to assess

Materials

Included:

- Geometric Figures
- Recording Sheet
- Answer Key

Not Included:

- Pencil

1

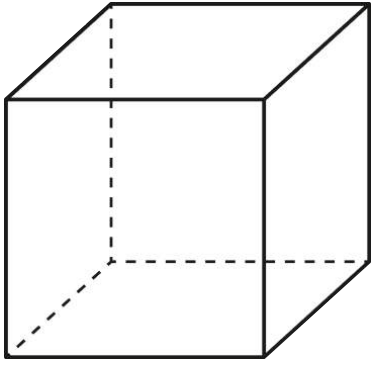

2

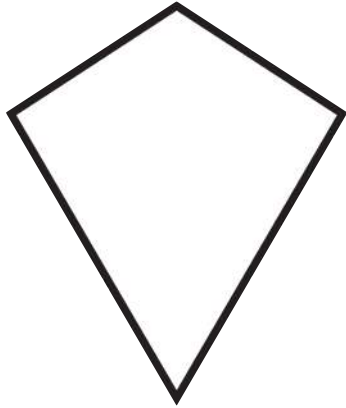

3

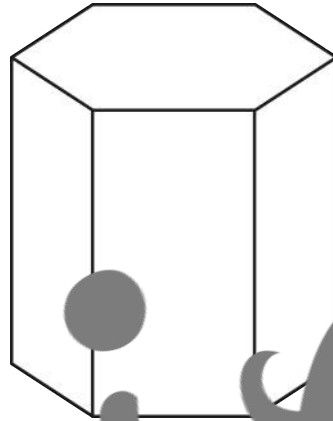

4



5

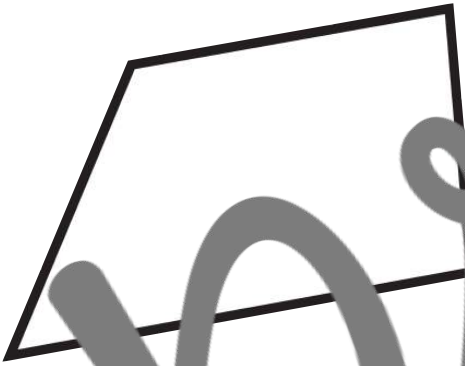

6



7



8

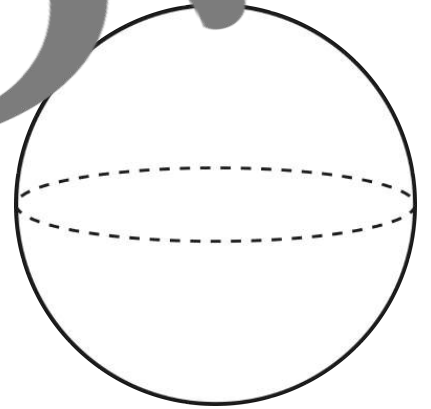

9

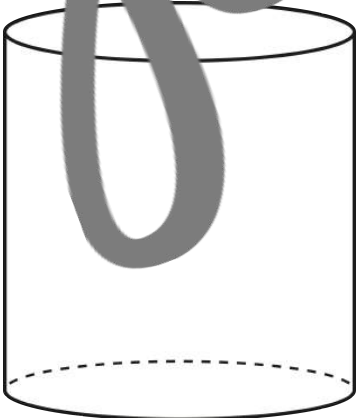

10

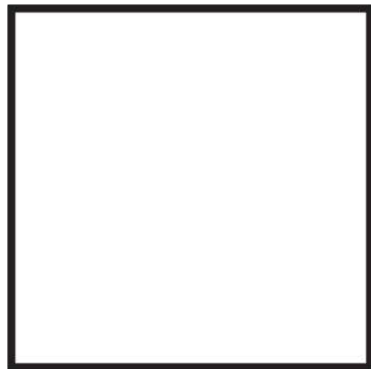

11

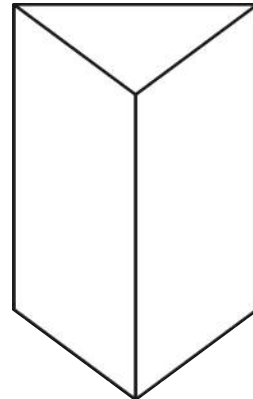

12

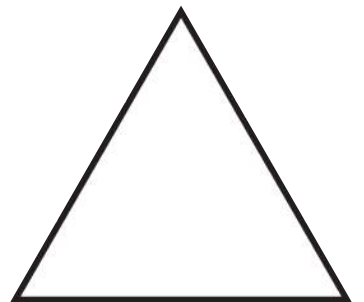

Name _____ # _____ Date _____

DESCRIBE IT RESPONSE SHEET

Name and describe each figure using geometric language.

1	2	3
4	5	6
7	8	9
10	11	12

DESCRIBE IT

ANSWER KEY

1 Cube 3D Six faces, eight vertices, and twelve edges	2 Quadrilateral sometimes known as a kite 2D four sides, four angles, and four corners	3 Hexagonal Prism 3D two hexagonal faces, six rectangular faces, twelve vertices, and eight edges
4 Pentagon 2D five sides, five angles, and five corners	5 Quadrilateral 2D four sides, four angles, and four corners	6 Cone (one) One circular face, one curved surface, and no edges or vertices
7 Trapezoid 2D four sides, four angles, and four corners	8 Sphere 3D no sides, vertices, or edges all points are equidistant from the center	9 Cylinder 3D two circular faces and one curved surface no edges or vertices
10 Square 2D four sides, four angles, and four corners, all sides are equilateral	11 Triangular prism 3D two triangular faces, three rectangular faces, six vertices, and nine edges	12 Triangle 2D three sides, three angles, and three corners

QR CODES

Scan the "START" card and follow the directions to use all cards stopping at the "END" card.

TEACHER SUGGESTIONS

QR CODES

- In this activity students are asked to scan QR codes and follow the directions to find the geometric figure identified.
- This activity can be used in a variety of ways:
 - ✓ Small groups with teacher guidance
 - ✓ Partner activity for practice
 - ✓ Independently to assess

Materials

Included:

- QR Code Cards

Not Included:

- A device capable of scanning QR Codes such as a smartphone or tablet

START

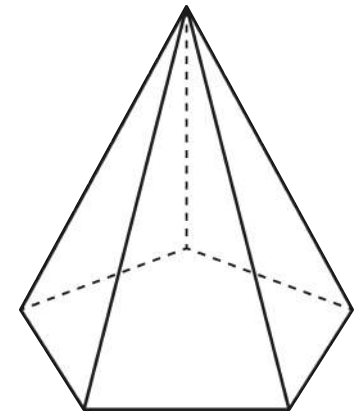
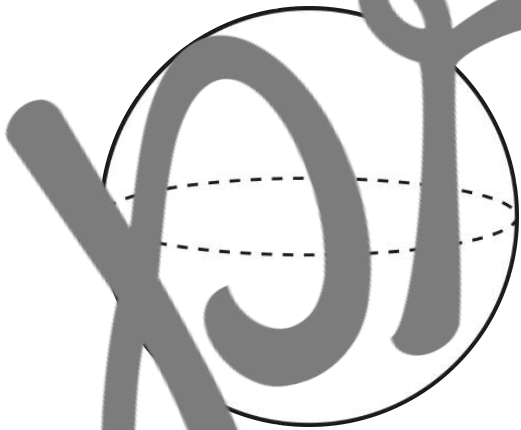
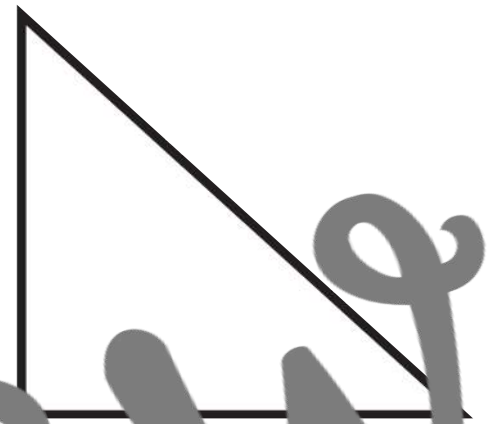
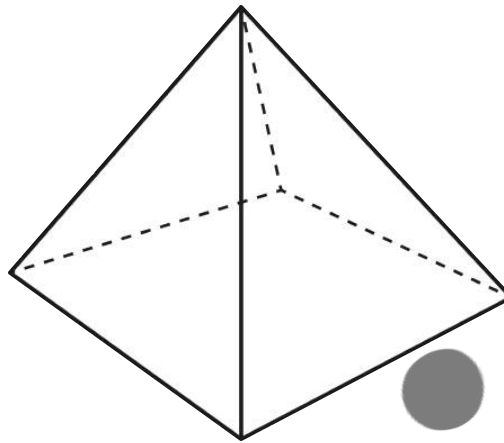

online

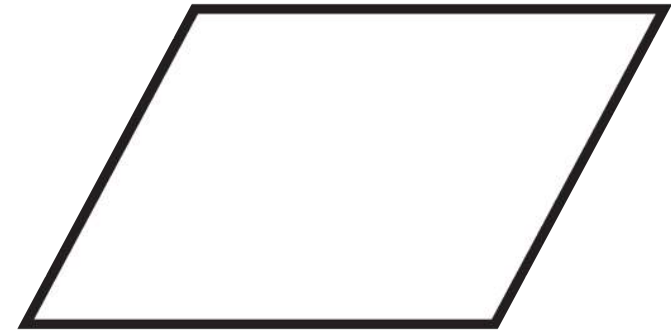
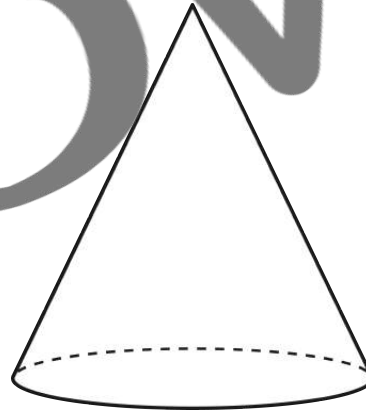
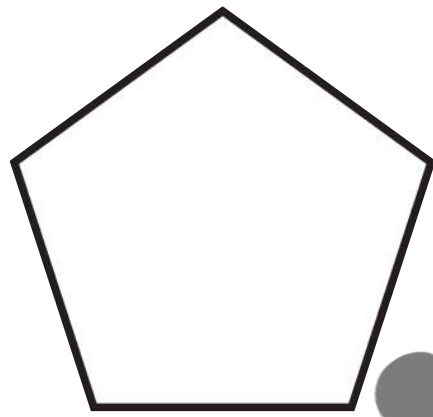
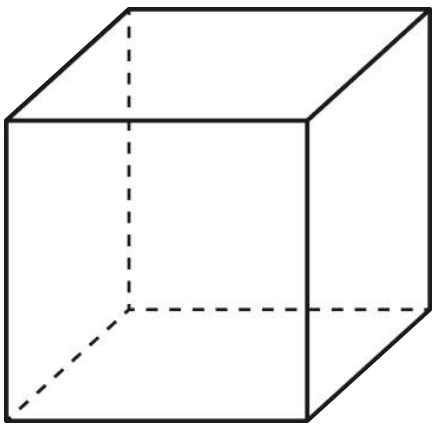

online

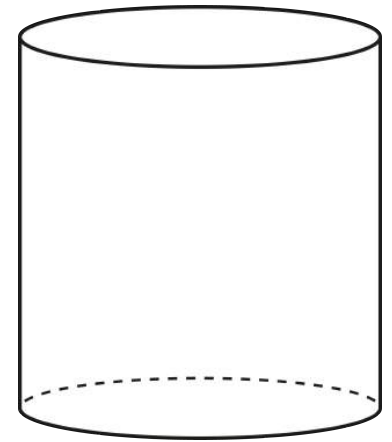
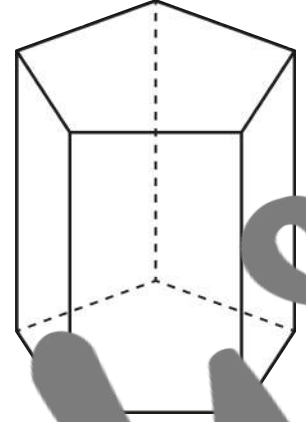
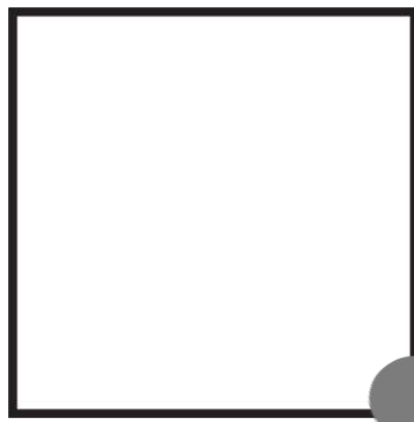
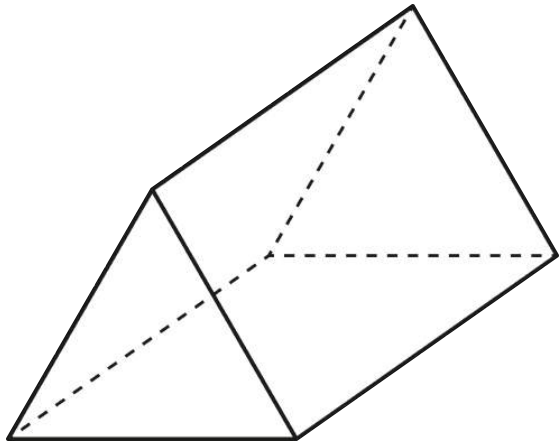

END

prisms

MATCH MACHINE

Create a drawing out of 2D figures. Then write a procedural text describing your drawing so that a friend could recreate the same drawing.

TEACHER SUGGESTIONS

MATCH MINE

- In this activity students are asked to create a drawing out of 2D figures then write a procedural text describing their drawing so that someone else could recreate it.

This activity can be used in a variety of ways.

- ✓ Small group with teacher guidance
- ✓ A partner activity for practice
- ✓ Independently to assess

Materials

Included:

- Shapes for Tracing
- If using these, I would recommend copying on cardstock

- Recording Sheet

Not Included:

- Pencil
- Answer Key

GEOMETRIC SHAPES FOR TRACING

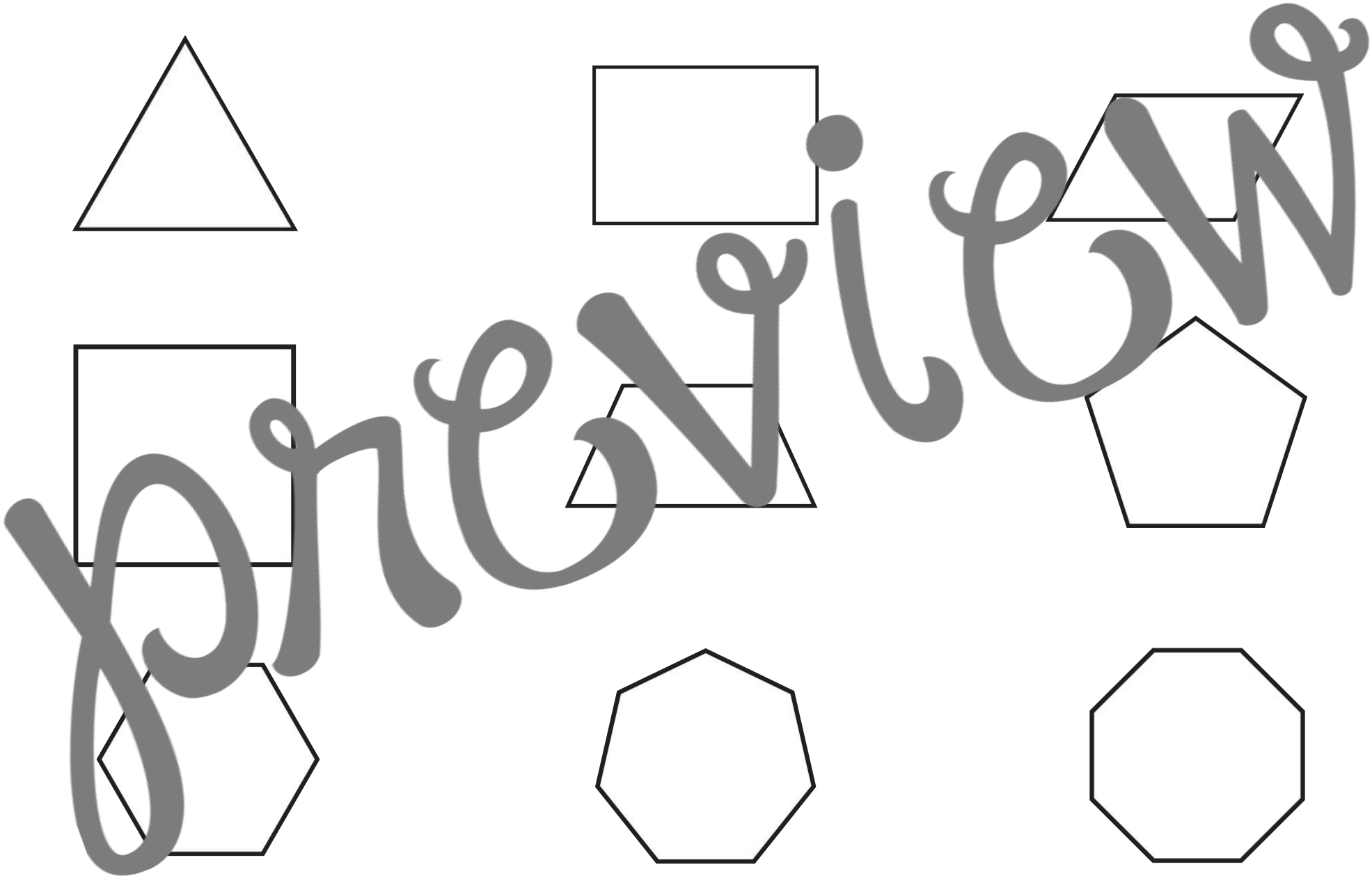
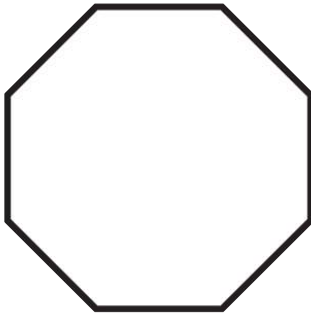
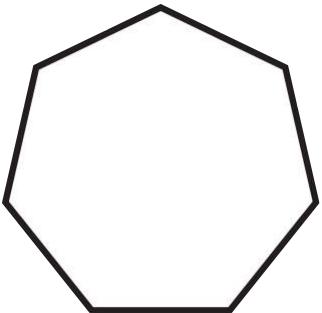
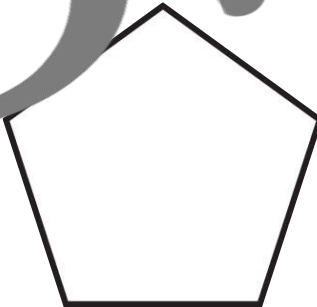
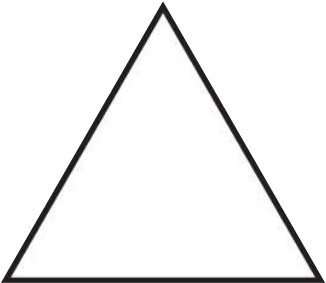

GEOMETRY MONSTER

Roll the die and follow the directions to draw a monster out of geometric figures.

TEACHER SUGGESTIONS

GEOMETRY MONSTER

- In this activity students are asked to roll a die to complete a work page giving them directions on how many geometric figures to use when drawing a monster.
- This activity can be used in a variety of ways:
 - ✓ Small group with teacher guidance
 - ✓ A partner activity for practice
 - ✓ Independently to assess

Materials

Included:

- Work Page
- Die
 - You can use a regular six sided die instead

Not Included:

- Pencil
- Answer Key

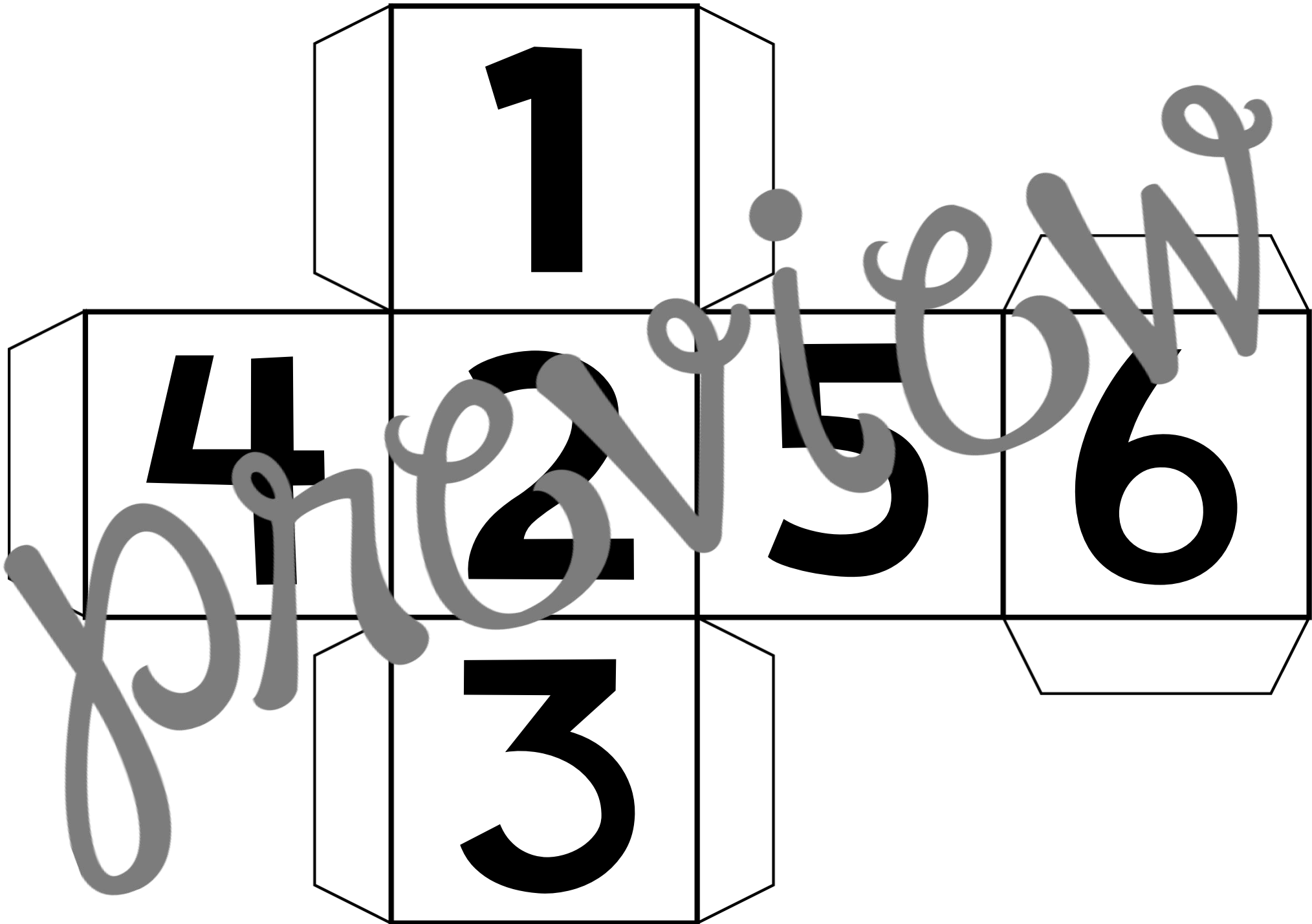

Name _____ # _____ Date _____

GEOMETRY MONSTER WORK PAGE

Roll the die to fill in the blank for each direction, and then use the back of this page or another paper to create your geometry monster.

Your monster should have ____ pentagonal eyes on each head.

Your monster should have ____ rectangular arms.

Your monster should have ____ triangular legs.

Your monster should have ____ hexagonal feet on each leg.

Your monster should have ____ parallelogram heads.

Your monster should have ____ circular hands on each arm.

All other body parts are up to you!

Name _____

Date _____

TEST BRIDGE QUESTIONS

1. Which statement is NOT true of a parallelogram?

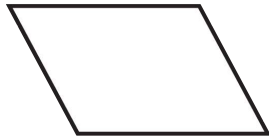

- a. It has four sides
- b. It has four angles
- c. It has two sets of parallel lines
- d. It has at least one right angle

3. Matha describes a figure as having two triangular faces, three rectangular faces, six vertices, and nine edges. What figure is he describing?

- a. a triangular pyramid
- b. a triangle
- c. a pentagonal prism
- d. a triangular prism

2. The following shape is all except:



- a. a square
- b. a pentagon
- c. a triangle
- d. a parallelogram

4. How many edges does a rectangular prism have?

- a. 12 edges
- b. 6 edges
- c. 8 edges
- d. 16 edges

TEST BRIDGE ANSWER KEY

1. Which statement is NOT true of a parallelogram?

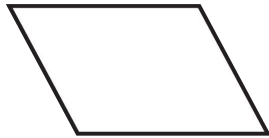

- a. It has four sides
- b. It has four angles
- c. It has two sets of parallel lines
- d. It has at least one right angle

2. The following shape is all except:



- a. a square
- b. a pentagon
- c. a triangle
- d. a parallelogram

3. Matha describes a figure as having two triangular faces, three rectangular faces, six vertices, and nine edges. What figure is he describing?

- a. a triangular pyramid
- b. a triangle
- c. a pentagonal prism
- d. a triangular prism

4. How many edges does a rectangular prism have?

- a. 12 edges
- b. 6 edges
- c. 8 edges
- d. 16 edges

Terms of Use: ©2016TeachingintheFastLaneLLC. All rights reserved. Purchase of this product entitles the purchaser the right to reproduce the pages for ONE CLASSROOM ONLY. Duplication for more than one classroom such as another teacher, grade level, school, or district is strictly forbidden without written permission from the author. Copying any part of this product and placing it on the internet in any form is strictly forbidden and is a violation of the Digital Millennium Copyright Act (DMCA).

Thank you for your purchase. If you have time, please rate this product and leave me some feedback on how I can improve my products. All constructive criticism is greatly appreciated.

PLEASE VISIT MY TEACHERSPAYTEACHERS STORE
Teaching in the Fast Lane
FOR MANY DIFFERENT PRODUCTS!

<http://www.teacherspayteachers.com/Store/4th-Grade-Racers>

teachinginthefastlane.com



Digital Papers by Sassy Designs

©2016TeachingInTheFastLaneLLC

